

AGRIEMACH LTD

Wayfarers, Old Domewood, Cophorne, West Sussex, Rh10 3HD
 Tel: (01342) 713743 Fax: (01342) 719181 e-mail: info@agriemach.com

INSTRUCTIONS MANUAL, SPARE PARTS, MAINTENANCE AND CONFORMITY DECLARATION

(Revised November 2003)

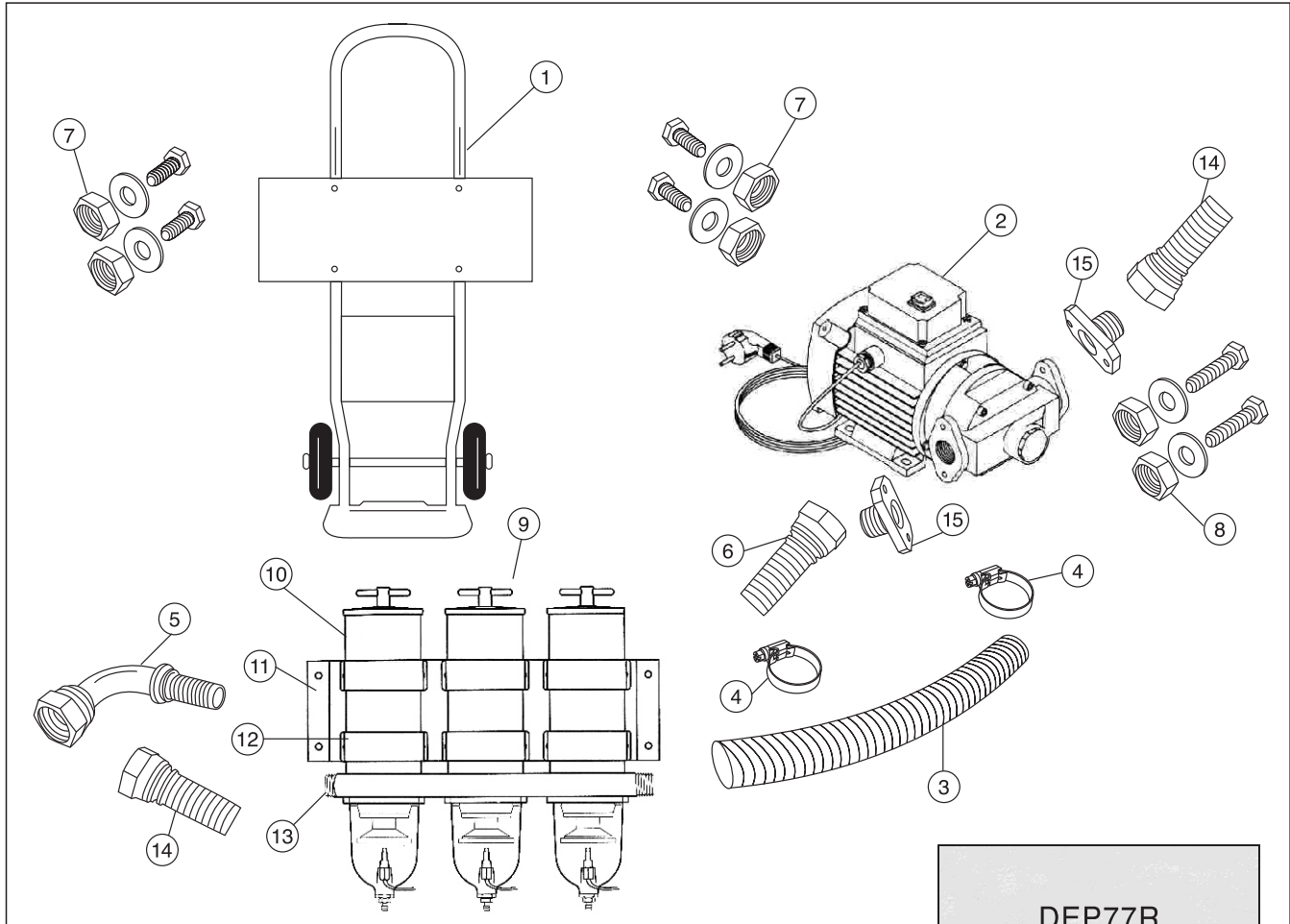

DEP77R

DRAWING	DESCRIPTION	PART NUMBER	QUANTITY
1	Trolley	CB20	1
2	Self suction pump (see breakdown)	AG88	1
3	Springwell hose 1"	M2	1
4	Hose clamps	M3	2
5	Elbow type fitting 1"	6104.16.16	1
6	Loose nut straight hose fitting 1"	6102.16.16	1
7	Hardware kit filter support	CT8C	4
8	Hardware kit pump support	CT6B	4
9	Separator filter assembly (3 units)	C377/1000FH	1
10	Single fuel / water filter separator (see breakdown)	C31000FH	3
11	Separator filter assembly support	C318998	1
12	Filter clamp	C311815-101	6
13	Fuel admission and return filter collector	T1"	2
14	Admission collector adapter	R1"	2
15	Close pump adaptor	H1	2

AGRIEPURE SYSTEM 3

MOBILE DIESEL TANK CLEANING SYSTEM

52LPM FLOW RATE

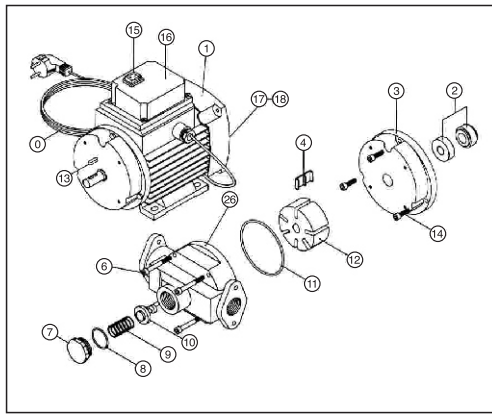

- 0.- 800900010. Power plug and cord.
- 1.- 000301001. Motor 0.5 HP.
- 2.- 804601003. Seal.
- 3.- 000301016. Motor Lid.
- 4.- 000302009. 6 blades set.
- 6.- 805400001. Screw M-6x55 DIN.912.
- 7.- 000302008. Bypass Lid.
- 8.- 803100019. -ring Bypass 30x3 NBR.
- 9.- 000302005. Bypass spring.
- 10.- 805606101. Bypass valve.
- 11.- 803100020. O-ring pump body 85x4.
- 12.- 000302010. Roll F-211.
- 13.- 000302002. Cotter pin 5x5x20.
- 14.- 805400002. Screws M-6 x 16 DIN.912.
- 15.- 807400003. Switch.
- 16.- 000301223. Connections box.
- 17.- 030001002. Fan.
- 18.- 030001003. Fan lid.
- 26.- 000302101. Pumps body with clamps.

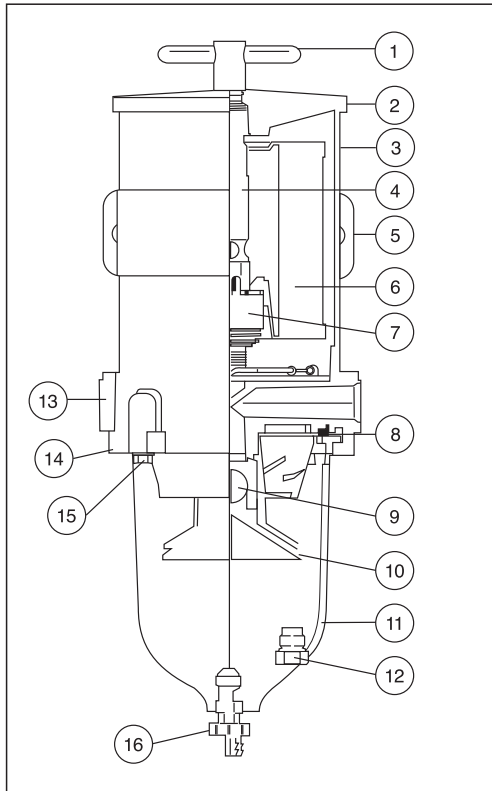

- 1.- C311-1945. T- handle.
- 2.- C311-1927-01. Top lid.
- 3.- C311021-103. Outer Cylinder.
- 4.- C311-1930. Return Tube.
- 5.- C311815-103. Body Clamp Bracket.
- 6.- C320205M. 2 microns element.
- 7.- C311-1953. Spring valve.
- 8.- C311007. Square cut gasket.
- 9.- C311028B. Check ball.
- 10.- C311-1939. Turbine centrifuge.
- 11.- C311-1938. See-thru Bowl.
- 12.- C322838. Sensor coupling.
- 13.- C311-1776. Body.
- 14.- C311037A. Bowl ring.
- 15.- C311542. Capscrew (4).
- 16.- C330476. Self-venting drain.

FEATURES

- Designed to clean tanks of 5.000 lt. or more
- Flow rate: 52 lpm
- Filtration:
 - Filtering media:
 - 2 microns absolute filtration Aquablock paper
 - Element with bypass system
 - Big filtering media surface
 - Transparent bowl with drain valve
 - Prefiltration through turbine located in the fuel inlet
- Electric pump:
 - Recirculation bypass available
 - Motor 0.5 HP self-ventilated with dust protection 220 VCA 50Hz single phase
 - Bypass pressure: 1.4 – 1.6 bar
 - Heavy duty cycle
- Consumption: 3 – 6 A.
- R.P.M.: 1,380 rpm.
- Protection IP-55
- Weight of the whole unit: 42 Kg.
- Height: 980 mm.
- Width: 650 mm.
- Length: 700 mm.

NOTE: Each C377/1000FH has a service seals kit under ref number C3111404.

TROUBLE SHOOTING

PROBLEM	SOLUTION
The equipment works but there is no fuel circulation.	<ul style="list-style-type: none"> - Check aspiration line - Check outlet line - Check for proper pump operation; check for saturation of pump filter (single and double models) - Check the bypass valve (triple model) - Check for saturation of the turbine filtering element
The pump operates slowly	<ul style="list-style-type: none"> - Check power line for inadequate voltage
The pump gets overheated	<ul style="list-style-type: none"> - Check the fluid properties and especially if its viscosity is too high. - Check saturation of the turbine filtering element - Check hose diameter.
The pump doesn't work	<ul style="list-style-type: none"> - Check wiring to the power line
Fluid leakage	<ul style="list-style-type: none"> - Check seals, fittings, and hose clamps

Fluids compatibility:

DEP77R is especially designed for cleaning tanks and gas oil (diesel) transfer and must not be used with any other liquid. DEP77R is adequate for its use in agriculture, construction, earth moving machinery, and industry.

Warnings:

This equipment requires clean air for self ventilation of the fuel pump. Each one of the three components of the filtering unit must be correctly closed in both the top lid and the bottom drain valve.

DEP77R must be used exclusively to clean gas oil (diesel).

To protect the pump it's indispensable to make sure that the filters have their filtering cartridges properly installed. The warranty does not cover damage of the pump in this case.

DO NOT FORGET TO TURN OFF THE PUMP USING THE SWITCH, once the cleaning operation is finished.

If the hoses are attached using clamps, they must be well tighten in order to avoid air intake

DO NOT OPERATE THE PUMP WITHOUT FLUID IN THE SYSTEM. Avoid spilling any liquid over the motor.

Plug in the power cord once it was made sure that the electric power is the same as the indicated on the motor technical information plate (for the voltage a tolerance of 10% is admitted). The Box-Switch assembly contains electric parts that must be manipulated only by specialized personal following all security norms. The pump motor must be correctly connected to ground.

The models AG-88 (0.5HP) and SAG-88 (0.5HP) are designed for heavy duty cycle and have self ventilation. The models AG-88 (0.5HP) and SAG-88 (0.5HP) are self suction type. If the pump does not suck liquid when starting it up stop it immediately and look for the reason.

Important note:

It is forbidden to use this equipment in explosion or fire risk environments. This pump must not be used to pump liquids that by law must be pumped using non flaming motors. Some examples of forbidden liquids are gasoline, acetone, solvents, etc. (Ref. regulation International Law IEC 79-10). Do not smoke near the pump or use it near fire. It could provoke an explosion and even death.

Maintenance:

It is recommendable to protect this equipment from the weather once it has been used and keep it dry and protected. After using the equipment the bowls must be dismounted and cleaned. The system must be emptied. The cartridges must be inspected periodically to check if they are dirty and change them if necessary.

Replace using always original cartridges.

HOW TO CLEAN A TANK

Agriepure equipment constitutes a system for tank cleaning by suctioning the liquid and returning it back to the tank once it has been cleaned using a filtration and water separating process.

Steps for effective tank clean:

1. it is recommended that the tank to be cleaned is over half full of fuel.
2. In fuel oil tanks live micro bioactive organisms that are attached to the walls in the form of a seaweed type sludge. About 24 hours before deep cleaning the tank, biocide must be added to the fuel. Biocide detached these micro organisms from the tank walls and allows them to remain suspended in the fuel. In this way they can now be removed with the Agriepure filtering process. The amount of biocide needed in each case can be calculated using this proportion: 1 bottle 473ml./16oz. will clean 4500 litres of diesel. With the aid of an air compressor and a hose (introduce the hose inside the tank) inject compressed air to create turbulence in order to lift the dirt from the bottom of the tank and get the dirt particles into the liquid.
3. It is recommended to introduce the hose until it reaches the bottom side of the tank, leaving its end totally free. In this way the movement generated permits an effective sweep of dirt.
4. Introduce the Agriepure suction hose deeply to get all the dirt and water. In some cases - depending on the available tank accesses/inlets - the hose could be used together with a piece of steel pipe to better drive the hose. This improves the hose access to different sections of the tank as needed.
5. For a complete clean of the fuel contained in the tank, the fuel must pass through the closed loop created by the Agriepure and the tank at least twice. The time required for the fuel to pass once through the closed loop depends on the Agriepure Diesel System being used, for example:
Tank: 1000 litres of diesel
Agriepure Diesel System 1: Flow rate of 25 litres per minute (LPM)
Time required for all of the diesel to pass once around the closed loop:
 $1000/25 = 40$ minutes
Time required for cleaning: $40 \times 2 = 80$ minutes
The different models of the Agriepure Diesel systems have different flow rates and filtering capabilities. The appropriate model must be used and this of course depends on the volume of the tank to be cleaned.
6. If the tank has several access points, it is recommended to use all these areas in the cleaning process. The suction hose could be introduced or connected in different ways.

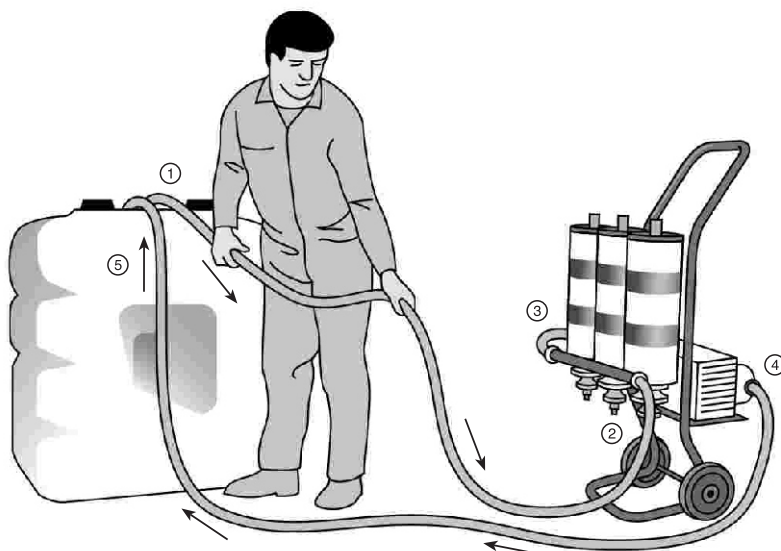

- 1.- Fuel suction outlet.
- 2.- Filter (fuel) inlet.
- 3.- Filter outlet towards pump inlet.
- 4.- Pump (fuel) outlet.
- 5.- Fuel return to tank.

BIOCIDE

Water produced by condensation (which because of its weight tends to accumulate at the bottom side of the tank) forms an interface where it contacts fuel. This interface favours the creation of micro-bioactive organisms that use diesel's hydrocarbons as nutrient. This effect produces sediments that grow very fast (these micro-organisms double their population each 20 minutes). Fuel could get completely deteriorated and the filter could get saturated very quickly. Furthermore, these bacteria produce acids that attack the metallic surfaces creating oxide.

Biocide eliminates these micro-organisms and any kind of seaweed grown thanks to the hydrocarbons contained in the fuel. Its formula contains antifoam and anticorrosion agents that protect the metallic surfaces.

Biocide avoids seaweed to grow at any temperature and also if they were still in the fuel when beginning the treatment. Biocide accomplishes total elimination after 12 hours, and prevents seaweed regeneration.

Biocide does not contain alcohol and therefore does not produce any damage to the engine's components



One bottle of **Biocide**
(16 oz / 473 ml) cleans
4,800 litres.

For other volumes please
find the proportion.

CONDITIONER +

During normal use an engine is exposed to a high number of different loads. Furthermore, engines normally work under the influence of different climatologic conditions. The engine performance is directly related to the quality of the fuel that it burns.

Conditioner + is a multifunctional additive that protects and maintains fuel quality for one year. It includes detergents and increase three points the cetane index increasing considerably the engine power reducing escape emissions and helping the engine to work smoother.

Conditioner + improves substantially the start up and contributes to a more effective combustion. It reduces friction, engine temperature, improves its performance and enlarges its life.

Conditioner + keeps clean the injector and dissolve fuel rubbers and varnishes. A better atomization is obtained and consequently improves combustion, optimises consumption and reduces gases emissions.

One of the most important components of **Conditioner +** is the fuel stabilizer which delays oxidation and deterioration.

Conditioner + does not contain alcohol and therefore does not produce any damage to the engine's components.



One bottle of **Conditioner +**
(16 oz / 473 ml) cleans
1,185 litres.

For other volumes please
find the proportion.

NOTE: Biocide poured in the tank and mixed with fuel does not damage engines absolutely and is perfectly usable. Our Customer Service Department could answer any question you could have.

Warranty:

All Agriepure diesel tank cleaning systems carry a 2 year warranty from date of invoice that covers any manufacturers defects. During the warranty period, Agriemach Ltd, grants the replacement of the defective parts as long as it is delivered back to Agriemach Ltd for examination. The defective part will be assessed by our chief engineer to understand the problem and how it has happened.

The warranty does not cover misuse, carelessness, abuse, corrosion, incorrect installation of the product or any of its parts, use of non original spare parts or using the system for purposes other than specified at time of purchase.

All standard health and safety precautions must be followed while using the Agriepure system. Health and safety training is provided by your employer.

AGRIEMACH LTD

Wayfarers, Old Domewood, Copthorne, West Sussex, Rh10 3HD
Tel: (01342) 713743 Fax: (01342) 719181 e-mail: info@agriemach.com